



## SUBMITTAL DATA SHEET

Job Name:		Contractor:	
Location:		Distributor:	
Engineer:		Date:	
Submitted To:		Model No:	<b>Max 30e</b>
Schedule ID:		No. of Outlets:	

<b>Max Air Specifications</b>	<b>Max 30e</b>
BTUH Heating @ 180°F E.W.T.	39,382
BTUH Heating @ 170°F E.W.T.	35,769
BTUH Heating @ 160°F E.W.T.	32,159
BTUH Heating @ 150°F E.W.T.	28,553
BTUH Heating @ 140°F E.W.T.	24,951
BTUH Heating @ 130°F E.W.T.	21,356
DX Cooling (tons) <sup>1</sup>	1.0
Power	120/1/60
Nominal Airflow	350 cfm
Fan Motor HP - Type	1/3 Hp - ECM
Amps	5.7
G.P.M. Flow Rating	5
Copper Connection Size Ø	1/2"
Supply Air Connection	8"
Minimum Outlets <sup>2</sup>	5
Maximum Outlets	11
Return Air Size Required	12" x 14" min.
Physical Dimensions (L/W/H)	30"x14"x18-1/2"

1 Smaller condensers may be matched to fan coil when required (match tx valve to condensing unit size)

2 The median number of outlets should be used to achieve maximum DX cooling capacity for each model size



### Features

Accurate temperature control / 2-stage heating, 2-stage cooling or 2-stage heating/cooling applications / multiple air flow options / loop temperature sensing control option / multi-positional placement / easily installed / easily serviced / multiple return options / compact size / extensive warranty

## Accessories

QTY.	Description
	50-IPCE-18A-01a c/w TX Valve, R410a, Cased 'A' Coil
	MA24-50-1 DX Coil c/w Metering device and Freezestat, R-410a, Cased Slab Coil
	121-001 Diffuser c/w Damper
	125-001 Rough-In Kit (includes elbow, dust cap + take-off)
	107-001 Floor Extension riser (1.75")
	123-001 10' 2.5" flex duct assembly with connector
	124-001 5' 2.5" flex duct assembly with connector
	Circulating pump (c/w check valve) 1/2" sweat - field installed

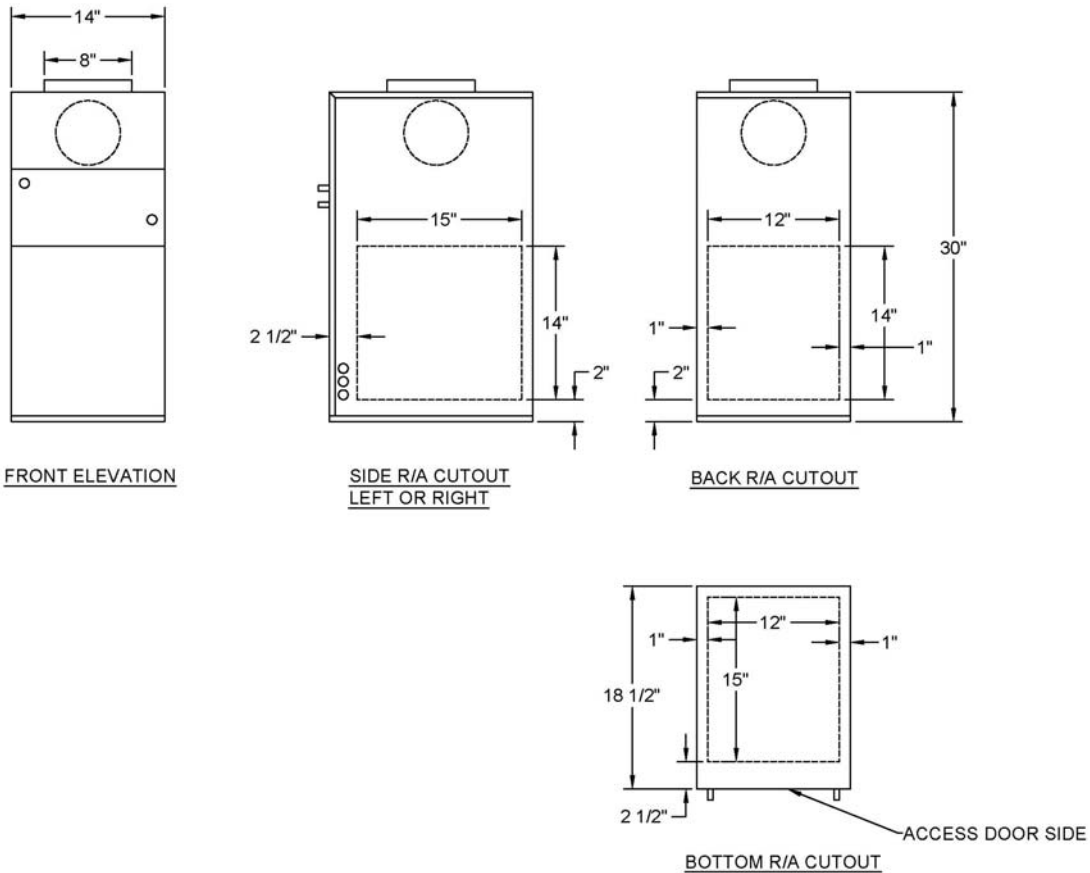

## Warranty

1 Year Parts and Labour, plus additional 12 months parts only, where applicable

NOTES: \_\_\_\_\_